

Modern Contesting

SM5AJV / SE5E



PILE

SEARCH & POUNCE

RUN

RATE

MULTI-MULTI

STUBBAR

SDR

SO2R

CW SKIMMER

Modern

MULTI-SINGLE

Contesting

RBN

BANDPASS FILTERS

MULTIPLIER RADIO

SO2V

SIX-PACK

INBAND RADIO

STACKMATCH

SO2R

- **SO2R – Single Operator 2 Radio**
- "Ropar du inte CQ förlorar du!"
- Du får bara sända på ett band i taget
- SO2R ett måste för att vara med i toppstriden

HÅRDVARA

ANTENNER

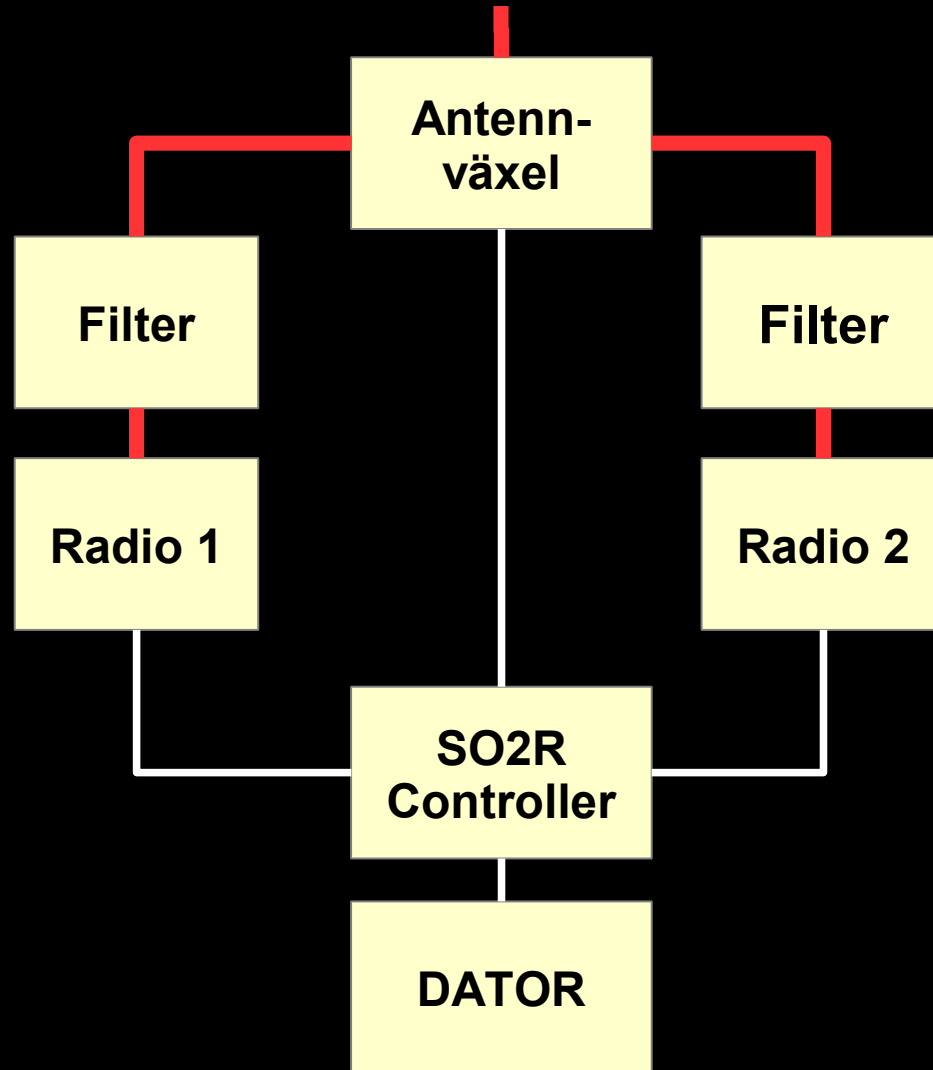

FILTER

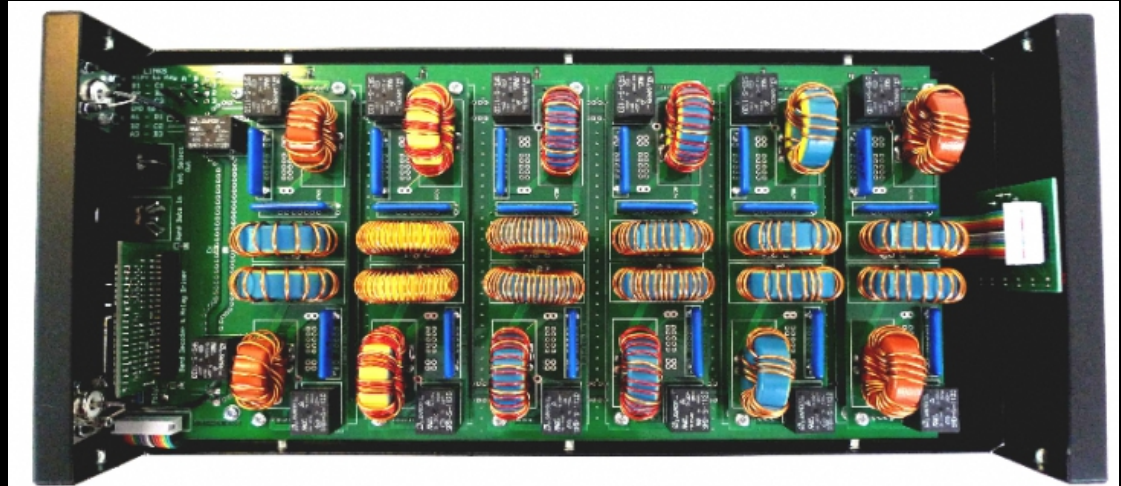

W3NQN: ca -30 till -90 dB



Stub: ca -20 dB



Dunestar: -30 till -50 dB

Läs mer på: <http://audiosystemsgroup.com/BandpassFilterSurvey.pdf>

ANTENNVÄXEL



STACKBOX



SO2R-Controller



TAKTIK

SO2R - Tre nivåer

- Nivå 1: Basic
 - Radio 2 används för att kolla bandöppningar
- Nivå 2: Avancerat
 - Radio 2 används för multipliers och QSO
- Nivå 3: Expert
 - Radio 2 används för att köra pile-up

SO2R – Nivå 1

- Radio 2 används för hitta bandöppningar
- Lyssna mycket
- Kanske hitta en ledig frekvens att börja ropa CQ på
- ... kanske ropa CQ på det nya bandet innan du flyttar?

SO2R – Nivå 2

- Radio 2 används för att köra QSO och Multipliers
- Vanligaste sättet att köra SO2R
- Man behöver inte synkronisera sina QSO

Exempel: OH2BH (op. OH6KZP) i SAC CW

| | | | | | | | | | | | |
|-------|----|------------|------|-------|-----|-----|-------|-----|-----|---|-----|
| 14004 | CW | 2013-09-21 | 1711 | OH2BH | 599 | 726 | DM3F | 599 | 51 | 2 | |
| 14004 | CW | 2013-09-21 | 1711 | OH2BH | 599 | 727 | HG7T | 599 | 85 | 2 | |
| 14004 | CW | 2013-09-21 | 1712 | OH2BH | 599 | 728 | EA6ZS | 599 | 31 | 2 | EA6 |
| 14004 | CW | 2013-09-21 | 1713 | OH2BH | 599 | 729 | R9DX | 599 | 250 | 3 | |
| 14004 | CW | 2013-09-21 | 1713 | OH2BH | 599 | 730 | DFOUK | 599 | 2 | 2 | |
| 14004 | CW | 2013-09-21 | 1713 | OH2BH | 599 | 731 | K9LJN | 599 | 45 | 3 | |
| 21055 | CW | 2013-09-21 | 1714 | OH2BH | 599 | 732 | EA6ZS | 599 | 32 | 2 | EA6 |
| 14004 | CW | 2013-09-21 | 1715 | OH2BH | 599 | 733 | N1IW | 599 | 20 | 3 | |
| 7002 | CW | 2013-09-21 | 1715 | OH2BH | 599 | 734 | EA6ZS | 599 | 33 | 2 | EA6 |
| 14004 | CW | 2013-09-21 | 1716 | OH2BH | 599 | 735 | DJOYZ | 599 | 72 | 2 | |

SO2R – Nivå 3

- Radio 2 används för att köra pile-up
- Antal QSO per timma ökar märkbart
- Synkning av QSO ett måste!
- Nivå 3 är den nivå som vinnarna kör!
- Det är svårt! Speciellt med löpnummer
- Öva med MorseRunner t.ex. i DxLog

Nivå 3: Exempel från SAC

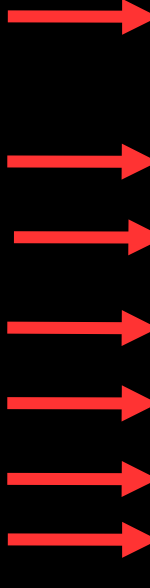

| | | | | | | | | | |
|-------|----|------------|------|------|-----|-----|--------|-----|----|
| 14036 | CW | 2014-09-20 | 1240 | OH0V | 599 | 129 | UA9FGJ | 599 | 30 |
| 21036 | CW | 2014-09-20 | 1240 | OH0V | 599 | 128 | IZ1LBG | 599 | 39 |
| 21036 | CW | 2014-09-20 | 1240 | OH0V | 599 | 131 | OM3CWY | 599 | 16 |
| 21036 | CW | 2014-09-20 | 1241 | OH0V | 599 | 132 | K3WW | 599 | 25 |
| 14036 | CW | 2014-09-20 | 1241 | OH0V | 599 | 130 | EA1CS | 599 | 3 |
| 21036 | CW | 2014-09-20 | 1241 | OH0V | 599 | 133 | K300 | 599 | 10 |
| 14036 | CW | 2014-09-20 | 1241 | OH0V | 599 | 134 | DG7EE | 599 | 13 |
| 21036 | CW | 2014-09-20 | 1241 | OH0V | 599 | 135 | K1RX | 599 | 25 |
| 21036 | CW | 2014-09-20 | 1242 | OH0V | 599 | 136 | N8II | 599 | 4 |
| 14036 | CW | 2014-09-20 | 1242 | OH0V | 599 | 137 | LZ9R | 599 | 50 |
| 21036 | CW | 2014-09-20 | 1242 | OH0V | 599 | 138 | N1KWF | 599 | 2 |
| 14036 | CW | 2014-09-20 | 1242 | OH0V | 599 | 139 | UR5MM | 599 | 46 |
| 21036 | CW | 2014-09-20 | 1242 | OH0V | 599 | 140 | HA1RJ | 599 | 32 |
| 14036 | CW | 2014-09-20 | 1243 | OH0V | 599 | 141 | RU6CS | 599 | 28 |
| 21036 | CW | 2014-09-20 | 1243 | OH0V | 599 | 142 | IZ5RVG | 599 | 16 |
| 14036 | CW | 2014-09-20 | 1243 | OH0V | 599 | 143 | R3FX | 599 | 29 |
| 21036 | CW | 2014-09-20 | 1243 | OH0V | 599 | 144 | RU9WZ | 599 | 32 |

**SAC CW 2014
OH0V**

op: OH6LI

Rate: 340

17 QSO på 3 minuter

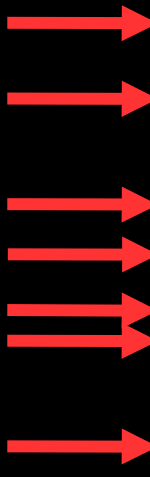

| | | | | | | | | | |
|-------|----|------------|------|------|----|------|--------|----|-----|
| 21000 | PH | 2011-10-08 | 1932 | OH8X | 59 | 1159 | N4JRZ | 59 | 1 |
| 21000 | PH | 2011-10-08 | 1932 | OH8X | 59 | 1160 | N6HRO | 59 | 1 |
| 14000 | PH | 2011-10-08 | 1932 | OH8X | 59 | 1161 | IV3IDP | 59 | 71 |
| 21000 | PH | 2011-10-08 | 1932 | OH8X | 59 | 1162 | N8DE | 59 | 240 |
| 14000 | PH | 2011-10-08 | 1933 | OH8X | 59 | 1163 | N7MZW | 59 | 11 |
| 21000 | PH | 2011-10-08 | 1933 | OH8X | 59 | 1164 | W6KPO | 59 | 1 |
| 21000 | PH | 2011-10-08 | 1933 | OH8X | 59 | 1165 | KI7DG | 59 | 1 |
| 14000 | PH | 2011-10-08 | 1933 | OH8X | 59 | 1166 | N9CDX | 59 | 2 |
| 21000 | PH | 2011-10-08 | 1934 | OH8X | 59 | 1167 | WD8QIJ | 59 | 7 |
| 21000 | PH | 2011-10-08 | 1934 | OH8X | 59 | 1168 | NY0T | 59 | 11 |
| 14000 | PH | 2011-10-08 | 1934 | OH8X | 59 | 1169 | OE2GRL | 59 | 5 |
| 14000 | PH | 2011-10-08 | 1934 | OH8X | 59 | 1170 | K6JJ | 59 | 10 |
| 21000 | PH | 2011-10-08 | 1934 | OH8X | 59 | 1171 | K0HCV | 59 | 3 |
| 21000 | PH | 2011-10-08 | 1935 | OH8X | 59 | 1172 | W0MOT | 59 | 2 |
| 14000 | PH | 2011-10-08 | 1935 | OH8X | 59 | 1173 | 9A5TIM | 59 | 39 |
| 21000 | PH | 2011-10-08 | 1935 | OH8X | 59 | 1174 | W6LAB | 59 | 3 |

**SAC SSB 2011
OH8X**

op: ES5TV

Rate: 320

16 QSO på 3 minuter

S02R – Level 3

RADIO 1

TX: TEST SK3W

RX: K1AR

TX: K1AR 599 173

RX: 599 003

TX: TU SK3W

RX: K3MD

TX: K3MD 599 175

Etc.

RADIO 2

RX: <brus>

TX: TEST SK3W

RX: ES5TV

TX: ES5TV 599 174

RX: 599 101

TX: TU SK3W

RX: PY1NX

MJUKVARA

Win-Test

WT - RDXC-CW_2016_A@SK3W.wt4 [A]

File Edit Operating Commands Messages Tools Windows Options Help

Summary

| BAND | SSB | CW | DUP | DXC | OBL | POINTS | AVG |
|--------------|-----------|-------------|----------|------------|------------|--------------|-------------|
| 160 | 0 | 118 | 0 | 42 | 36 | 760 | 6.44 |
| 80 | 14 | 283 | 0 | 53 | 62 | 2207 | 7.43 |
| 40 | 22 | 359 | 1 | 61 | 59 | 2910 | 7.64 |
| 20 | 36 | 437 | 4 | 75 | 68 | 3845 | 8.13 |
| 15 | 3 | 190 | 0 | 64 | 43 | 1367 | 7.08 |
| 10 | 2 | 24 | 0 | 16 | 5 | 130 | 5.00 |
| TOTAL | 77 | 1411 | 5 | 311 | 273 | 11219 | 7.54 |

FINAL SCORE: 6 551 896

Check callsign ...

| [3/12] | CW | SSB |
|--------|----|-----|
| 160 | ✓ | |
| 80 | ✓ | |
| 40 | ✓ | |
| 20 | ✓ | |
| 15 | ✓ | |
| 10 | ✓ | |

Check partial result

Check multipliers

| | | | | |
|------|-----|-------|-------|---------|
| 852 | 160 | 23:27 | LY9A | 599978 |
| 807 | 80 | 22:39 | LY9A | 599916 |
| 374 | 40 | 16:21 | LY2AJ | 599271 |
| 118 | 20 | 13:14 | LY6A | 599078 |
| 1259 | 15 | 07:55 | LY9A | 5991579 |
| 10 | | | | |

LY: Lithuania 20431
Az: 140° Lp: 320° SR: 0312z SS: 1737z

Radio 1

VFO A 40000
VFO B 40000

Rate

All bands - All modes
Last hour: 44 Q/h
10 last QSO: 79 Q/h
100 last QSO: 50 Q/h
Since 0700z: 39 QSO
- 15 last minutes -

Min: 24 Q/h
Moving graph compu
Continental dis

Time ON: 23 h 57 min
Time OFF: 0 min

All bands - All modes
Time by mult: 2 min 27 sec
1 QSO counts: 4 403 Pts
1 mult counts: 15 630 Pts
1 mult worth: 3.5 QSO

CW 34 WPM S

Contest Recorder

2016/03/20
07:55:42
RDXC

Statistics

QSOs

18:43:12 SK3W SR 0324z SS 16

| QSO | Bd | Mode | Time | Callsign | Sent No. | Rcvd | Mult | Pt |
|------|----|------|-------|----------|----------|----------|------|----|
| 1250 | 20 | CW | 07:48 | R3XA | 5991250 | 599 KG | 10 | |
| 1251 | 20 | CW | 07:48 | R3RA | 5991251 | 599 TB | 10 | |
| 1252 | 20 | CW | 07:48 | RA3AN | 5991252 | 599 MA | 10 | |
| 1253 | 15 | CW | 07:49 | R9QQ | 5991253 | 599 KN | 10 | |
| 1254 | 15 | CW | 07:50 | R0RC | 5991254 | 599 IR | 10 | |
| 1255 | 15 | CW | 07:50 | LZ2CH | 5991255 | 599 341 | C | 3 |
| 1256 | 20 | CW | 07:53 | LU1FAM | 5991256 | 599 1216 | C | 5 |
| 1257 | 20 | CW | 07:54 | UA3DER | 5991257 | 599 MO | 10 | |
| 1258 | 20 | CW | 07:54 | UA9NN | 5991258 | 599 OM | 10 | |
| 1259 | 15 | CW | 07:55 | LY9A | 5991259 | 599 1579 | C | 3 |

Secondary radio

RADIO 1 **RADIO 2**

Primary Secondary

Both Latch mode

FOCUS Check Band Scenario 3 Scenario 4

Scenario 5 Scenario 6 Scenario 7 DUAL RUN

RUN S/P

80 CW 5991494 599

DXLog.net

Summary

| BAND | QSO | DUP | GRID | POINTS | AVG |
|--------------|-----------|----------|-----------|-----------|-------------|
| 80 | 26 | 1 | 12 | 52 | 2.00 |
| 40 | 7 | 0 | 4 | 14 | 2.00 |
| TOTAL | 33 | 1 | 16 | 66 | 2.00 |

FINAL SCORE: 1 056

Rate

All bands - All modes
 Last hour: 34 Q/h
 10 last QSO: 34 Q/h
 100 last QSO: 0 Q/h
 Since 1800z: 0 QSO

Time ON: 00:55
 Time off: 00:00

Run QSO: 17
 S&P QSO: 17
 Hour RUN QSO: 7
 Hour S&P QSO: 0

All bands - All modes
 Time by mult: 5 min 24 sec
 1 qso counts: 32 pts
 1 mult counts: 101 pts
 1 mult worth: 3.1 QSO

CW 24 WPM

Radio 1

VFOA **35000**

3528.0 SM3DTQ
 3535.8 SM6FAM

Radio 2

VFOB **70000**

Check multipliers

80
 40

SM: Sweden
 Az: 318 Lp: 138 SR: 0330z SS: 1833z

Check partials

SK50DB SK5A SK5LW SK5WB

N+1

SK5A

Operating info

Active mode
 Radio 1: RUN CW
 Radio 2: S&P CW

TX/RX status

| | RADIO1 | RADIO2 |
|----|--------|--------|
| TX | | |
| RX | | |

Listening: Radio 1
 RPT timer: 3.0 sec

CW speed
 24 WPM 26 WPM

Check callsign

| BAND | CW |
|------|----|
| 80 | |
| 40 | |

18:47:58 SE5E SR 0325z SS 1818z RUN S/P

| QSO | Freq | Band | Time | Callsign | Sent | Nr | Rcvd | Loc. | Pts | Mult | Stn |
|-----|--------|-------|-------|----------|------|-----|---------|--------|-----|------|-----|
| 26 | 3530.0 | 80 | 15:57 | SM3OH0 | 599 | 026 | 599 013 | JP811R | 2 | JP81 | R |
| 27 | 3530.0 | 80 | 15:57 | SM6Q | 599 | 027 | 599 010 | J067AN | 2 | | R |
| 28 | 3530.0 | 80 | 16:01 | SM2AVG | 599 | 028 | 599 015 | JP93RL | 2 | JP93 | R |
| 29 | 3530.0 | 80 | 16:03 | SM0CUH | 599 | 029 | 599 017 | J089XM | 0 | DUPE | R |
| 30 | 3530.0 | 80 | 16:03 | SM2BJS | 599 | 030 | 599 016 | KP03DU | 2 | KP03 | R |
| 31 | 3530.0 | 80 | 16:04 | SM5LSM | 599 | 031 | 599 010 | J089G0 | 2 | | R |
| 32 | 3530.0 | 80 | 16:06 | SM5BJT | 599 | 032 | 599 013 | J089TU | 2 | | R |
| 33 | 3530.0 | 80 | 16:07 | SM6GBM | 599 | 033 | 599 017 | J067BL | 2 | | R |
| 34 | 3530.0 | 80 | 16:12 | SM3XAX | 599 | 034 | 599 014 | JP82GJ | 2 | JP82 | R |
| 35 | 80 | 18:47 | SK5 | 599 | 035 | 599 | | | 0 | | R1 |
| 35 | 40 | 18:47 | | 599 | 035 | 599 | | | 0 | | R2 |

Radio 1: 2S 2N
 Radio 2: 51S

64 Points

Bandmap List

N1MM+

14200,00 USB Manual

File Edit View Tools Config Window Help

| CW | PH | | Snt | Rcv | Name | Comment | | | |
|-----|-----|----------------------------------|-----------------------|-----|----------------------------------|---------|-----|----|-----|
| 160 | 160 | | | | | | | | |
| 80 | 80 | | | | | | | | |
| 40 | 40 | <input checked="" type="radio"/> | <input type="radio"/> | Run | <input checked="" type="radio"/> | S&P | | | |
| 30 | 30 | F1 S&P | F2 | F3 | F4 | F5 His | F6 | | |
| 20 | 20 | F7 Rpt | F8 | F9 | F10 | F11 | F12 | | |
| 17 | 17 | Esc: Stop | Wip | Log | Edit | Mar | Sto | Sp | QRZ |
| 15 | 15 | Heading appears here when | | | | | | | |
| 12 | 12 | Call history UserText appears | | | | | | | |
| 10 | 10 | | | | | | | | |

Setting up radios bandmaps No Score 0

21200,00 USB Manual

File Edit View Tools Config Window Help

| CW | PH | | Snt | Rcv | Name | Comment | | | |
|-----|-----|-------------------------------|----------------------------------|-----|----------------------------------|---------|-----|----|-----|
| 160 | 160 | | | | | | | | |
| 80 | 80 | | | | | | | | |
| 40 | 40 | <input type="radio"/> | <input checked="" type="radio"/> | Run | <input checked="" type="radio"/> | S&P | | | |
| 30 | 30 | F1 S&P | F2 | F3 | F4 | F5 His | F6 | | |
| 20 | 20 | F7 Rpt | F8 | F9 | F10 | F11 | F12 | | |
| 17 | 17 | Esc: Stop | Wip | Log | Edit | Mar | Sto | Sp | QRZ |
| 15 | 15 | Heading appears here when | | | | | | | |
| 12 | 12 | Call history UserText appears | | | | | | | |
| 10 | 10 | | | | | | | | |

No Score 0

SK3W SO2R - Set-up



HJÄRNVARA

SO2R - HJÄRNVARA

- Det är inte HW/SW som är det viktiga i SO2R
- DET ÄR DU!
- För att bli bra måste man öva!

TU

KÖR SAC!



CW: 17-18 September

SSB: 8-9 Oktober